

RF REMOTE CONTROL PROGRAMMING

Program a Remote

Press the **S** button once

Press and hold either button on the remote you wish to program

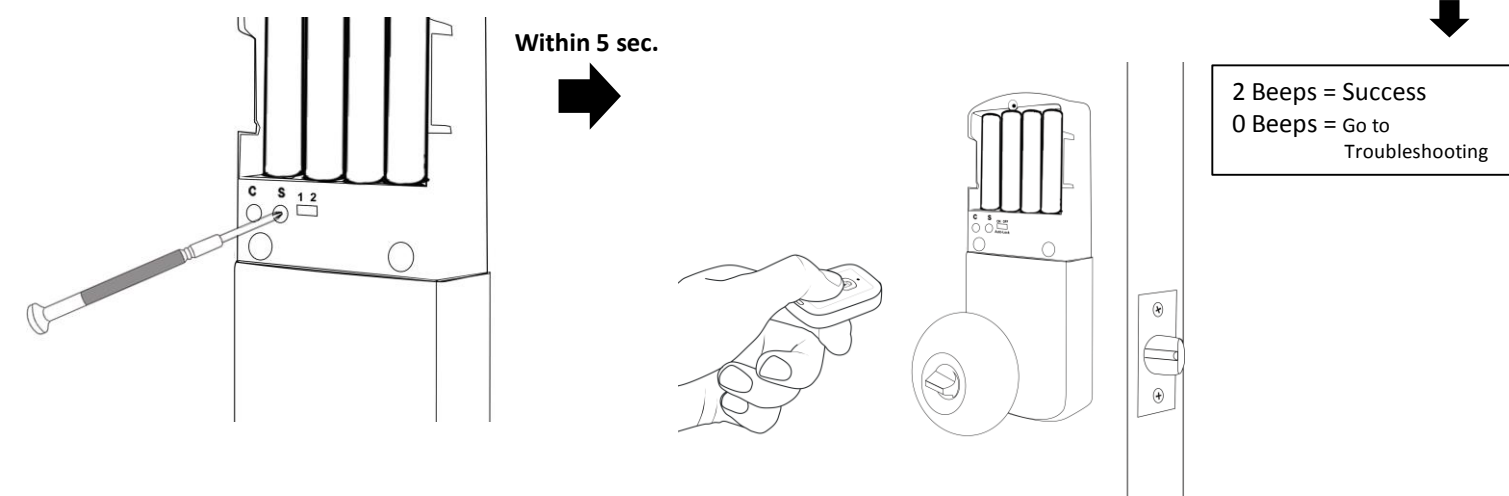

To clear all remotes

Press the **C** button once

Press and hold either button on the remote you wish to delete

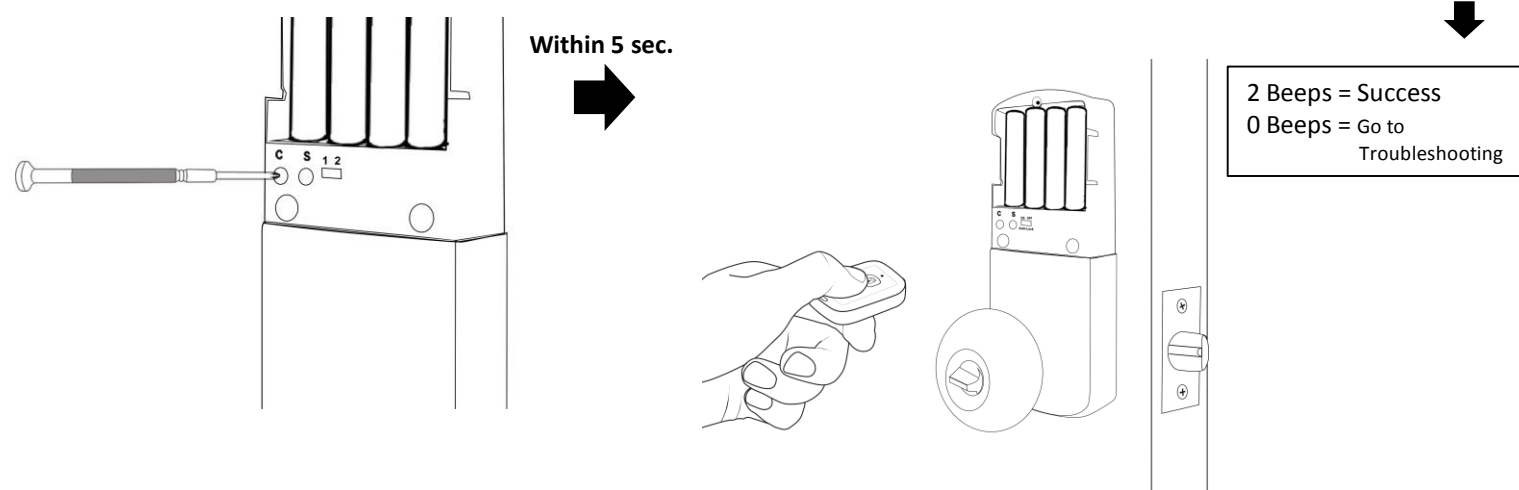

NOTE: This will delete all remotes stored in the memory and will program the remote you are using at that moment.

TROUBLESHOOTING

Low Batteries (Most Common Issue): To avoid any difficulties during set up, make sure you are using brand new AA alkaline batteries.

RF Remote Control Programming: Make sure the red light turns on when the buttons on the remote are pressed. If the red light does not turn on your issue may be battery related. If batteries are ok and the red light turns on but the remote still does not operate the door lock, give us a call during business hours to troubleshoot.

Remote Control Range: RF remote control works 10ft - 30ft away without obstructions. If the range is lower than this, it may be due to interference from an outside source. Give us a call during business hours to troubleshoot.

INSTEON Programming: If you are having issues operating the lock via INSTEON, please call INSTEON technical support at 1-866-243-8022

If you are unable to get your lock to work please give us a call during business hours.

US Live Tech Support: 1-800-355-0157 M-F 9am - 5pm PST (English & Spanish)
Warranty shipments are always shipped promptly.

WARRANTY

MiProducts Corporation warrants to the original residential user of this product that it will be free from defects in materials and workmanship, under normal use, for 1 year from the date of purchase. User must provide a copy of original purchase receipt. This warranty does not cover abuse or misused products or products used in commercial applications. All mechanical components carry a limited warranty, for a period of 25 years from the date of purchase. The finish of the exterior of this lock carries a limited warranty of the lifetime of the unit against deterioration due to normal weather conditions. This warranty does not apply to locks that have been improperly installed, modified, put to a use other than designed, or subjected to acts of God (such as floods, lightning, earthquakes, etc.) This warranty is limited to repairing or replacing of this lock only at MiProducts Corporation's sole discretion. MiProducts Corporation will NOT be liable for the cost of installing, removing, nor reinstalling this product, nor direct, indirect, or consequential damages to persons or property resulting from the use of this product. This warranty only covers the cost of replacement parts, it does not cover shipping & handling fees.

To implement this warranty please give us a call during business hours at 1-800-355-0157, or visit www.milocks.com.



Model WKK

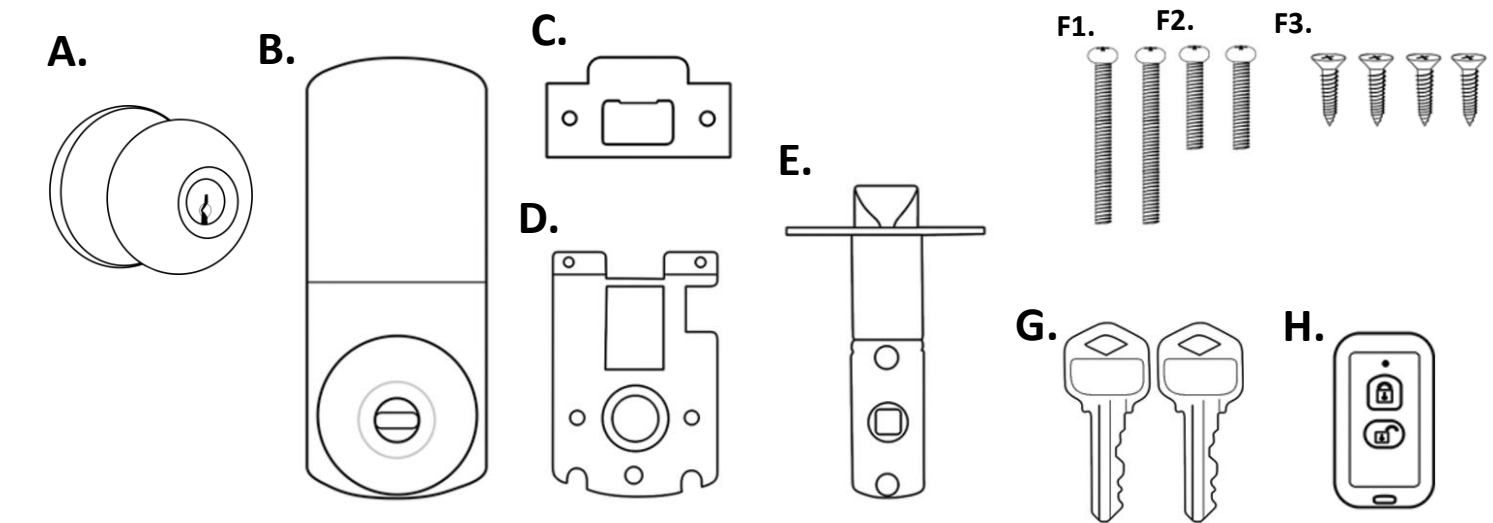

GENERAL WARNINGS & CAUTIONS:

- The back module (Part B.) needs to be protected from the weather
- Remote works up to 30' without obstructions

Tools Required (not included):

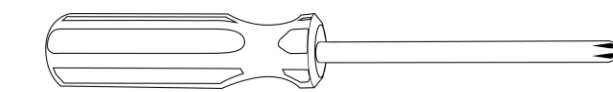

X1 Phillips Screwdriver

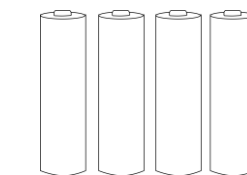

X4 AA Batteries

Auto-Lock Switch on Part B.:

On the back module (part B), there is a switch labeled "On-Off" which controls the auto-lock function.

On = Automatic lock after 10 seconds. (shortens battery life up to 50%)

Off = Does not automatically lock.



For assistance with assembly or installation, parts and customer service, call:
1-800-355-0157 (English & Spanish)
9am – 5pm PST Mon. – Fri.
North America

Battery Precautions

- Do not mix old with new batteries.
- Do not use rechargeable batteries.
- Remove batteries from product when storing for extended periods of time.
- Do not dispose of batteries in fire as they may explode. Please follow your local battery disposal procedure.
- Do not puncture batteries. Electrolyte leakage from the batteries is corrosive and can cause serious harm to the eyes or skin. If swallowed, the electrolyte can be toxic.
- Do not allow conductive materials such as jewelry or metal tools to make contact with the batteries which may cause a short circuit. With a short circuit, the batteries and conductive material can become extremely hot and cause burns.

Register Your Product

- Although we hope you never have to deal with a warranty claim during the use of our product, you should submit a product registration to validate the warranty. This keeps it on record with us so you don't have to save a receipt or record of any kind. Just give us a call and we will take care of you.
- Register at www.milocks.com

1. Adjust Latch Backset

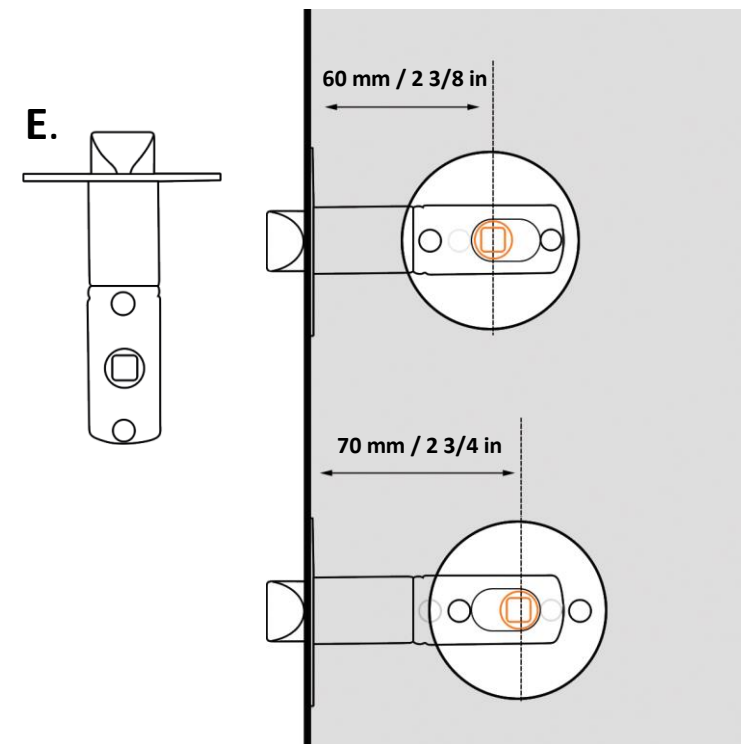

2. Install Door Latch

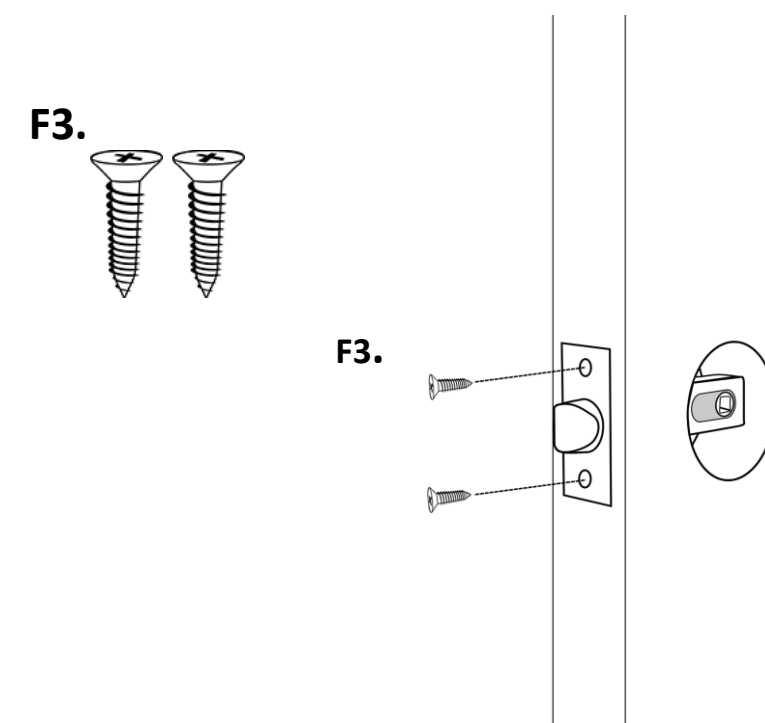

3. Mount Front Module

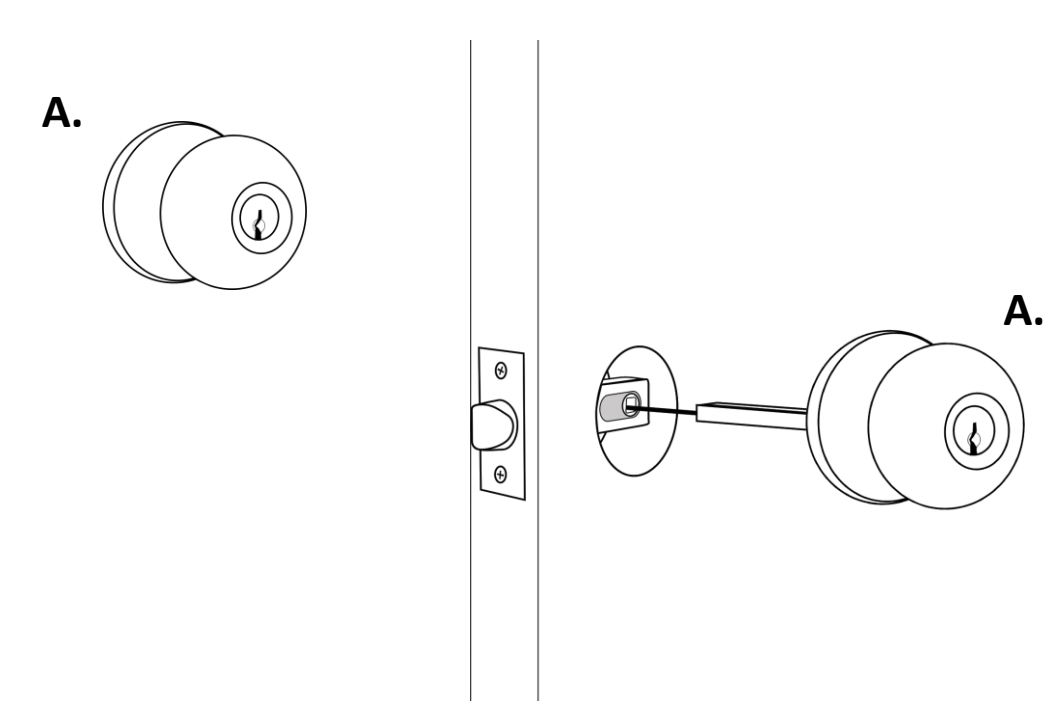

4. Fasten Back Mounting Plate

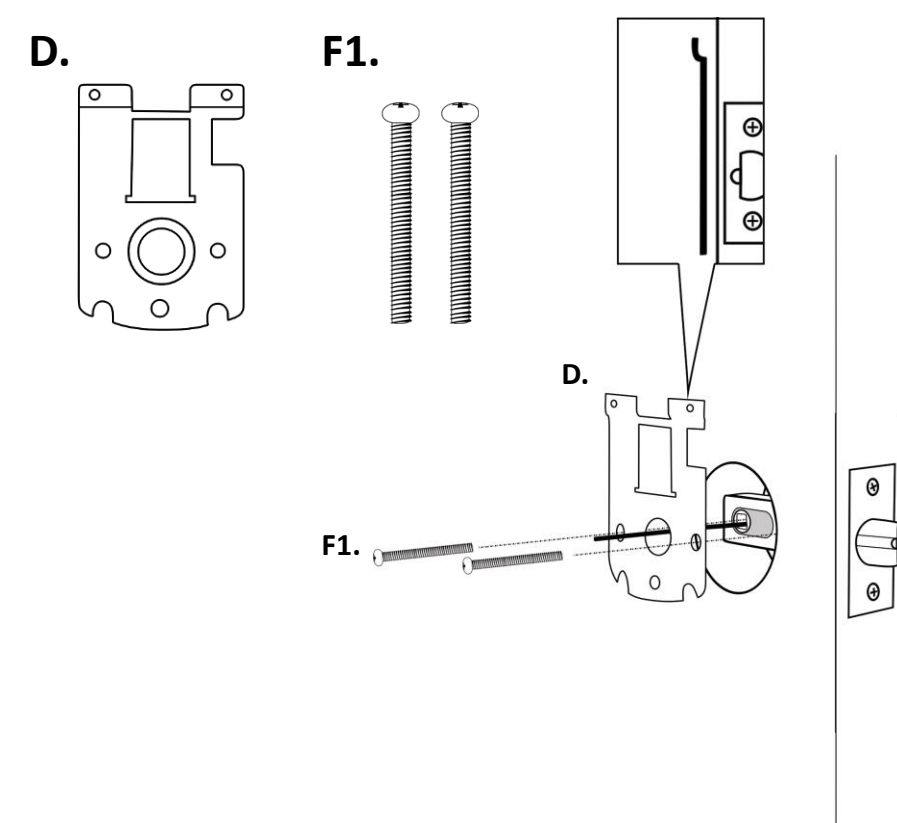

5. Mount & Fasten Back Module

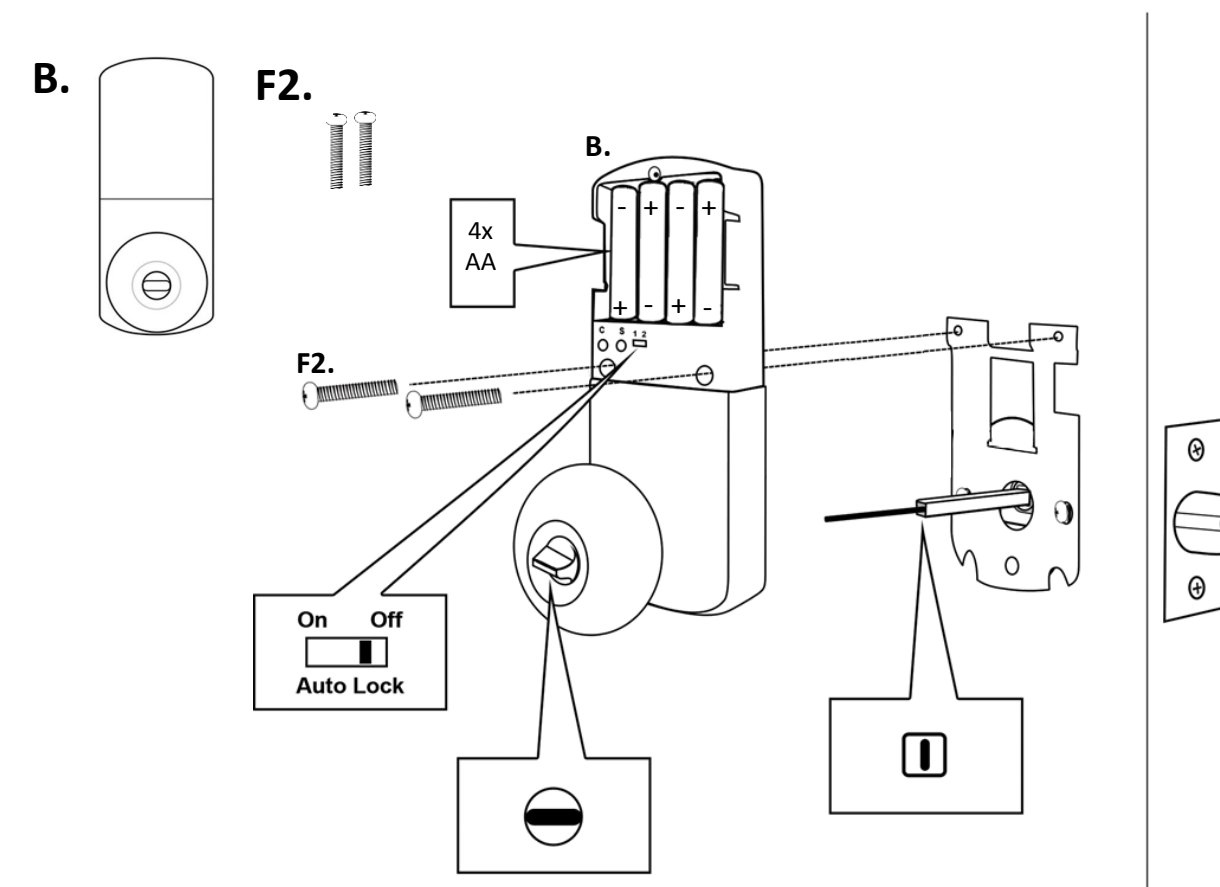

6. Install Battery Cover

